

# MONROE Dual Throat Air Scrubber



- Wet type dust collector
- Removes long, stringy solids
- Efficiencies up to 99.9%
- No moving parts in wash zone
- Minimum maintenance
- Capacities from 2,000 to 45,000 CFM

## Remove Airborne Particulate Matter

The Monroe Dual Throat Air Scrubber is designed to remove both heavy and light airborne particulate matter from industrial exhaust systems, as well as flue and process gasses. The Monroe Dual Throat Air Scrubber is a completely self-contained unit that needs only to be connected to normal plant electrical, water and air systems.

## Recirculate Clean Air

In many installations, such as buffing and polishing, metal finishing and grinding, foundry operations,

etc., it is possible to recirculate clean, contaminant-free air back to the work area. This reduces the cost of plant ventilation systems and climate control needs.

## Proven High Efficiency

Monroe Dual Throat Air Scrubbers are currently operating continuously at high efficiency in many types of industrial installations throughout the United States, Mexico and Canada.

Independent laboratory tests have shown that many of these units are removing various types of airborne particulate at efficiencies up to 99.9%, even on heavy particulate loads.

## A High Volume Water Injector

The Monroe Dual Throat Air Scrubber utilizes a high volume wash water injector system that removes airborne particulate by delivering an initial surface impingement shock to heavy inlet dirt loads.

## Dual Adjustable Scrubbing Throats

High velocity atomization takes place as the inlet air is directed through the fixed and dual adjustable scrubbing throats. The easily adjustable dual throats balance the pressure drop through the airflow system at start-up or after system changes are made.

This design feature eliminates the need for ductwork dampers and blast gates that are prone to particulate build-up and require periodic maintenance. In addition, the increase in pressure drop in the wash zone improves the overall efficiency of the system.



## Ideally Suited for Removal of-

- Cast iron machining fines
- Chemical fumes
- Coal dust
- Explosive dusts
- Fiberglass fines
- Forging smoke and fumes
- Foundry dust and fumes
- Buffing operations
- Machining dusts
- Metal deburring dust
- Paint overspray
- Synthetic resin fumes

## MONROE Dual Throat Air Scrubber

### Double Row Moisture Eliminators

After passing through the turbulent dual throat wash zone, the air impinges on the liquid surface, changes direction and then continues through deflectors and to a large, double row moisture eliminator section. Water droplets in the airstream are removed and drain back to the wash liquid reservoir tank.

The clean, dry air is then recirculated to the work area or discharged through exhaust ducts.

### Minimum Wash Liquid Requirements

Waste water disposal problems are eliminated under normal operating conditions. Each unit has a self-contained wash liquid reservoir and recirculating pump. An automatic water valve replenishes wash liquid lost through evaporation.

Optional automatic drag conveyors for removal of heavy, settled particulate and oil recovery units provide additional wash liquid cleaning for more efficient operation.

### Materials of Construction

The Monroe Dual Throat Air Scrubbers are constructed of mild

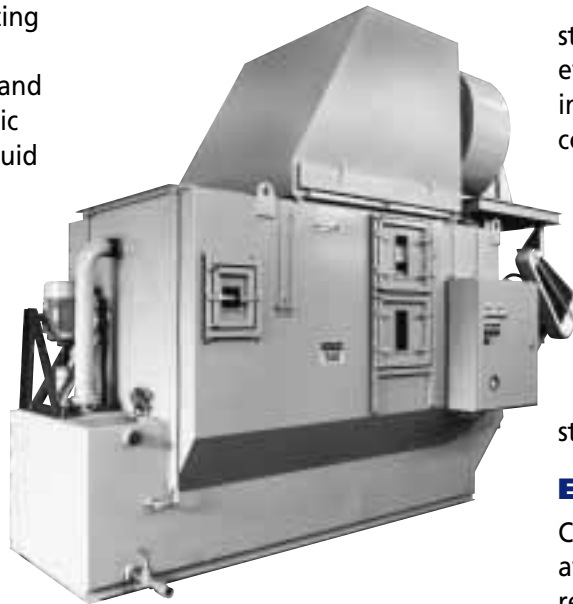
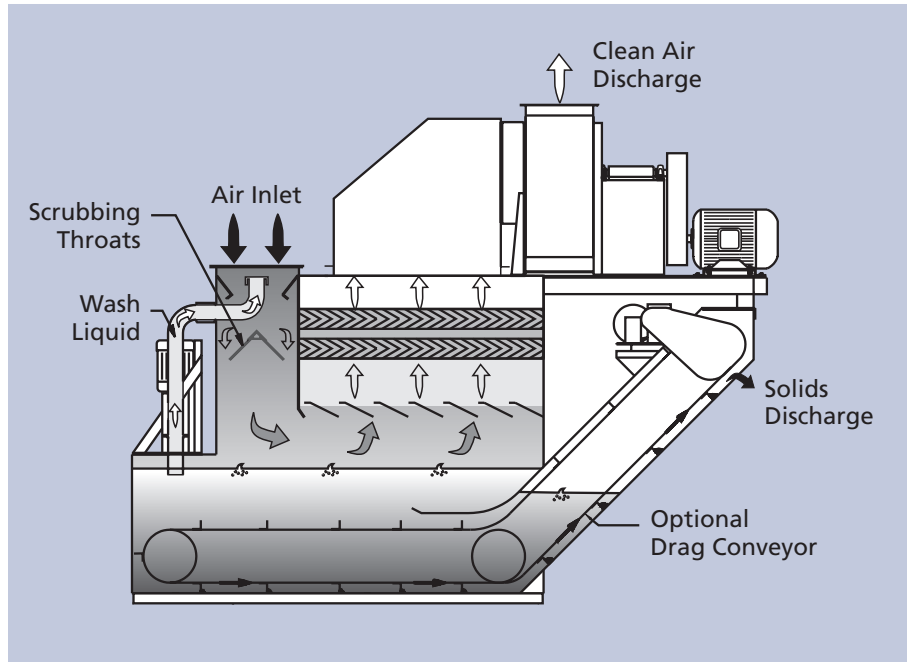

steel for most applications. However, where the intended use will involve corrosive or highly abrasive contaminants, other construction materials such as stainless steel or reinforced fiberglass, as well as special coatings are available.

Moisture eliminators also are constructed of materials suitable for the intended application, including polyethylene or stainless steel.

### Electrical Controls

Complete electrical controls are available to meet customer specific requirements.

### Many Configurations Available

Monroe Dual Throat Air Scrubbers can be configured to meet specific needs. Units can be equipped with drag conveyors to remove heavy, settled particulate and oil recovery units to remove accumulated oil.



**MONROE  
ENVIRONMENTAL**

*Manufacturer of Industrial Filtration Systems*

11 Port Avenue, P.O. Box 806  
Monroe, Michigan 48161 USA  
Phone: 1-800-992-7707 or 734-242-7654  
Fax: 734-242-5275

[www.monroeenvironmental.com](http://www.monroeenvironmental.com)

©2000 Monroe Environmental Corporation